

1、主要参数 Main Characteristics

2、用途 Applications

- 高频开关电源 High frequency switching mode power supply
- DC/DC 变换器 DC/DC Converter
- 高频开关与同步整流 high-frequency switching and synchronous rectification
- UPS 电源 Uninterruptible Power Supply
- PFC 功率因数校正 Power Factor Correction

3、产品特性 Features

- 超低通态电阻的高密度单元设计 High density cell design for ultra low Rdson
- 低 Crss (典型值 12pF) Low Crss (typical 12pF)
- 低栅漏电荷降低开关损耗 Low gate to drain charge to switching losses
- 产品全部经过雪崩测试 100% avalanche tested
- 高抗 dv/dt 能力 Improved dv/dt capability
- RoHS 产品 RoHS product

V_{DSS}	60	V
I_D	80	A
P_D	130	W
$R_{DS(ON)TYP}$	5.3	m Ω

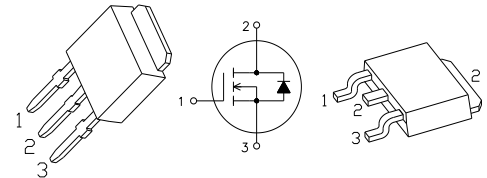

TO-251S

TO-252

1 栅极(G) 2 漏极 (D) 3 源极(S)

4. 电特性 Electrical Characteristics

4.1 极限值 Absolute Ratings (T_C = 25°C)

参数名称 Parameter	符号 Symbol	额定值 Value	单位 Unit
漏极-源极电压 Drain-Source Voltage	V_{DSS}	60	V
连续漏极电流 Drain Current -continuous	I_D	T _C = 25 °C	80
		T _C = 100 °C	15
最大脉冲漏极电流 ^(注 1) Drain Current - pulse ^(note 1)	I_{DM}	320	A
栅源电压 Gate-Source Voltage	V_{GS}	±20	V
单脉冲雪崩能量 ^(注 4) Single Pulsed Avalanche Energy ^(note 4)	E_{AS}	300	mJ
二极管反向恢复最大电压变化速率 Peak Diode Recovery dv/dt	dv/dt	3.0	V/ns
耗散功率 Power Dissipation	P_D	130	W
结温, 贮存温度 Operating and Storage Temperature Range	T _j , T _{stg}	150, -55~150	°C



www.jdsemi.cn

深圳市晶导电子有限公司

ShenZhen Jingdao Electronic Co.,Ltd.

CM80N06C

POWER MOSFET

4.2 电参数 Electrical Characteristics (T_c = 25°C)

参数名称 Parameter	符号 Symbol	测试条件 Tests conditions	最小 Min	典型 Typ	最大 Max	单位 Units
截止特性 Off-Characteristics						
漏源击穿电压 Drain-Source Voltage	BV _{DSS}	V _{GS} =0V, I _D =250μA	60			V
漏源击穿电压温度系数 Breakdown Voltage Temperature Coefficient	Δ BV _{DSS} / Δ T _J	I _D = 250 μA		0.71		V/°C
漏源漏电流 Zero Gate Voltage Drain Current	I _{DSS}	V _{DS} =60V, V _{GS} =0, 25°C V _{DS} =48V, V _{GS} =0, 125°C			1 100	μA
栅源漏电流 Gate-body leakage current	I _{GSS}	V _{GS} = ±20V			±100	nA
导通特性 On-Characteristics						
静态导通电阻 Static Drain-Source On-Resistance	R _{DS(on)} *	V _{GS} =10V, I _D =20A V _{GS} =4.5V, I _D =20A		5.3 6.5	6.0 7.8	mΩ
阈值电压 Gate Threshold Voltage	V _{GS(th)}	V _{DS} =V _{GS} , I _D =250μA	1.2	1.8	2.2	V
跨导 Forward Transconductance	g _{fs}	V _{DS} =10V, I _D =20A	35			S
脉冲宽度 tp≤380μs, 占空比 δ≤2%						
动态特性 Dynamic Characteristics						
输入电容 Input capacitance	C _{iss}	V _{GS} =0V, V _{DS} =30V f=1.0MH		2100		pF
输出电容 Output capacitance	C _{oss}			359		
反向传输电容 Reverse transfer capacitance	C _{rss}			12		
开关特性 Switching Characteristics						
开启延迟(时间) Turn-On delay time	t _{d(ON)}	V _{DD} = 30V V _{GS} = 10V I _D = 20A R _G = 4.7Ω		9		nS
上升时间 Turn-On rise time	t _r			3		
关断延迟(时间) Turn-Off delay time	t _{d(OFF)}			31		
下降时间 Turn-Off Fall time	t _f			5		
栅极电荷 Total Gate Charge	Q _g	I _D =20A, V _{DS} =30V V _{GS} = 10V		36.6		nC
栅源电荷 Gate-Source charge	Q _{gs}			6.7		
栅漏电荷 Gate-Drain charge	Q _{gd}			5.8		

地址：深圳市宝安区石岩街道洲石路中集创谷产业园 B 栋 1-3 层 电话：0755-29799516 传真：0755-29799515



www.jdsemi.cn

深圳市晶导电子有限公司

ShenZhen Jingdao Electronic Co.,Ltd.

CM80N06C

POWER MOSFET

源-漏二极管特性 Drain-Source Diode Characteristics						
源漏二极管连续电流 (Note 2) Maximum Continuous Drain -Source Diode Forward Current (Note 2)	I_{SD}	$T_c = 25\text{ }^\circ\text{C}$			60	A
源漏二极管脉冲电流 Maximum Pulsed Drain-Source Diode Forward Current	I_{SDM}				240	A
源漏二极管正向压降 (Note 3) Drain-Source Diode Forward Voltage (Note 3)	V_{FSD}	$I_{SD}=20\text{A}, V_{GS}=0$			1.2	V
反向恢复时间 Reverse recovery time	t_{rr}	$I_{SD}=20\text{A}, T_j = 25\text{ }^\circ\text{C}$ $dI_F/dt=100\text{A}/\mu\text{s}, V_{GS}=0\text{V}$		40		nS
反向恢复电荷 Reverse recovery charge	Q_{rr}			50		nC

参数名称 Parameter	符号 Symbol	额定值 Value	单位 Unit
热阻 (结到壳) Thermal Resistance, Junction to Case	$R_{\theta JC}$	0.96	$^\circ\text{C}/\text{W}$
热阻 (结到环境) Thermal Resistance, Junction to Ambient	$R_{\theta JA}$	62.5	$^\circ\text{C}/\text{W}$

注:

- 1 重复脉冲, 宽度由最高结温限制
- 2 表面安装在 FR4 板上, $t \leq 10$ 秒
- 3 脉冲测试: 脉冲宽度 $\leq 300\ \mu\text{s}$, 占空比 $\leq 2\%$.
4. EAS 条件 : $T_j=25\text{ }^\circ\text{C}$, $V_{DD}=30\text{V}$, $V_G=10\text{V}$,
 $L=0.5\text{mH}$, $R_g=25\Omega$

Notes:

- 1 Pulse width limited by maximum junction temperature
- 2 Surface Mounted on FR4 Board, $t \leq 10$ sec.
- 3 Pulse Test: Pulse Width $\leq 300\ \mu\text{s}$, Duty Cycle $\leq 2\%$.
- 4 EAS condition : $T_j=25\text{ }^\circ\text{C}$
 $V_{DD}=30\text{V}$, $V_G=10\text{V}$, $L=0.5\text{mH}$, $R_g=25\Omega$

5. 特性曲线 Characteristics Curve

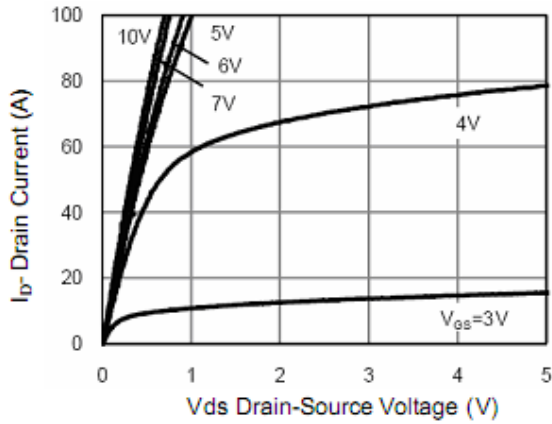

Figure 1 Output Characteristics

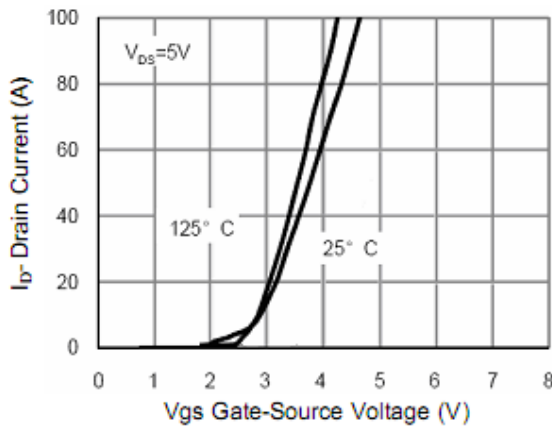

Figure 2 Transfer Characteristics

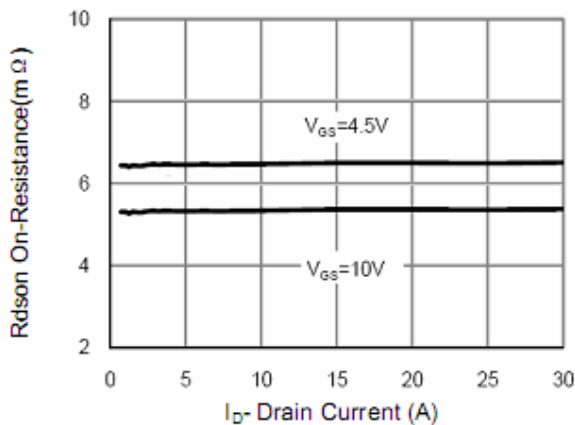

Figure 3 Rdson- Drain Current

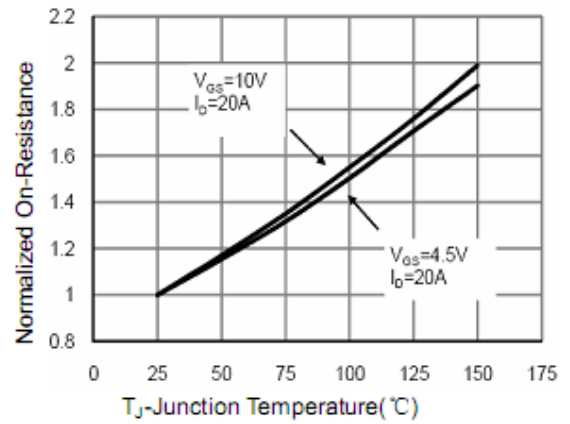

Figure 4 Rdson-Junction Temperature

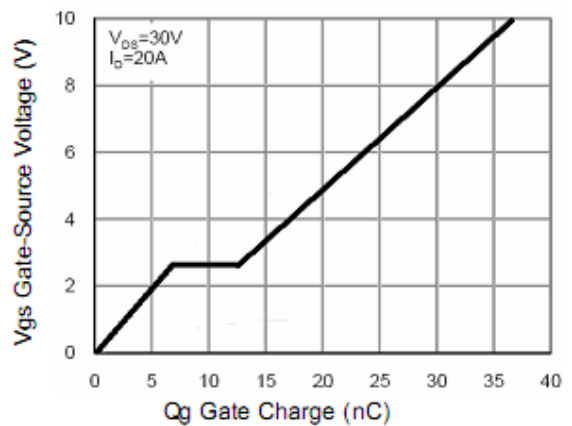

Figure 5 Gate Charge

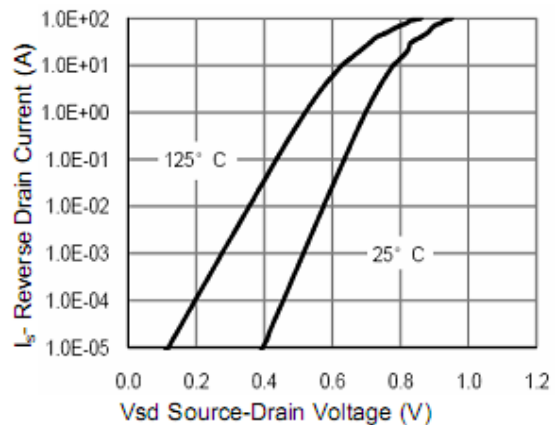

Figure 6 Source- Drain Diode Forward

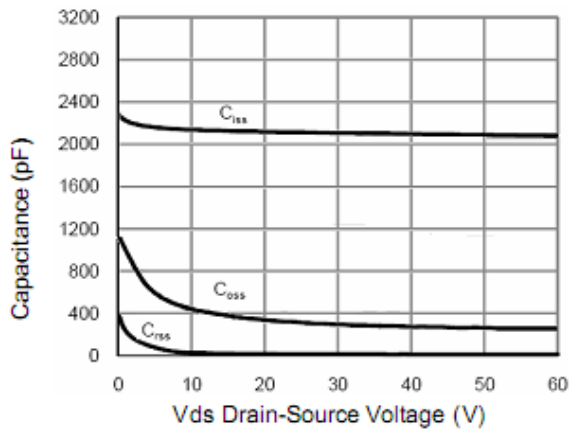

Figure 7 Capacitance vs Vds

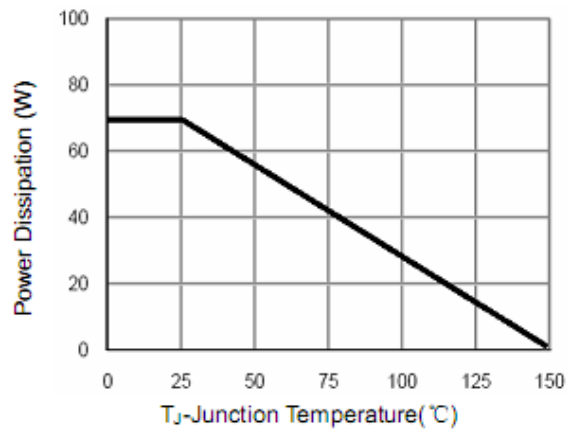

Figure 9 Power De-rating

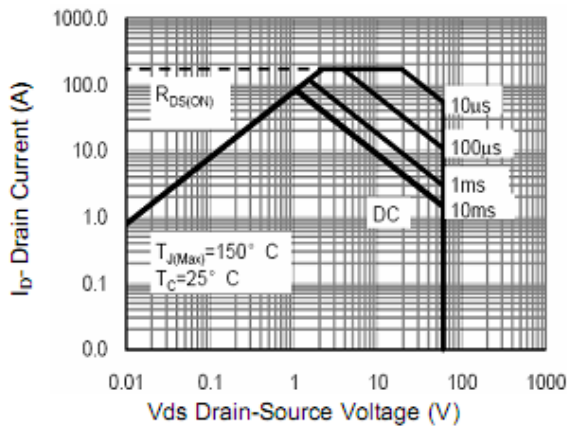

Figure 8 Safe Operation Area

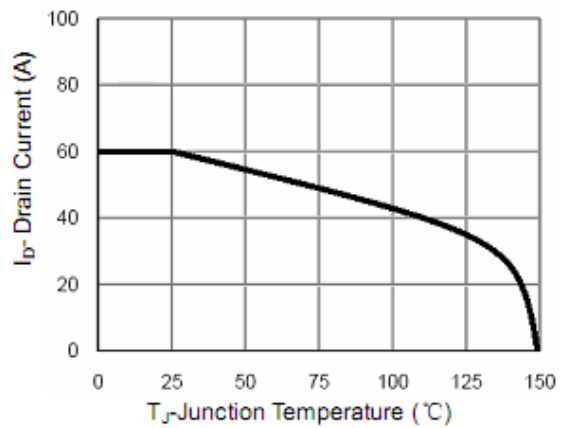

Figure 10 Current De-rating

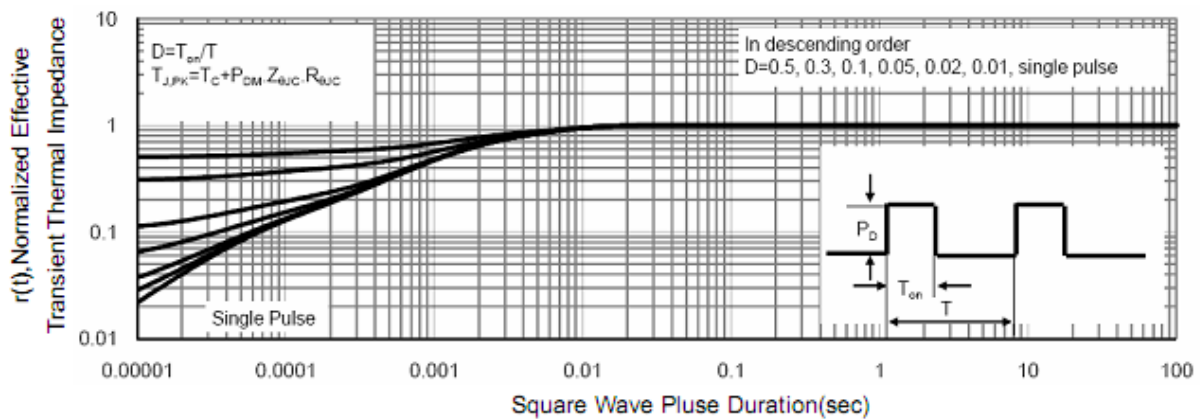
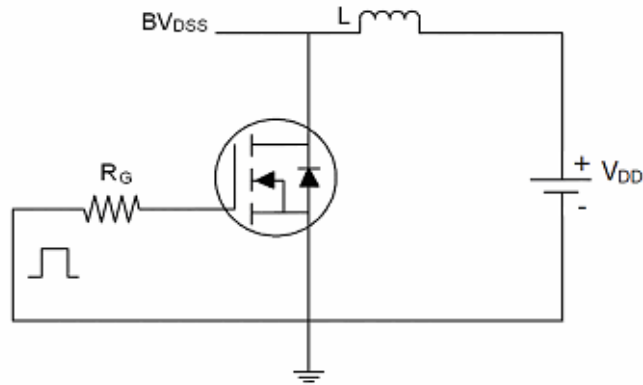

Figure 11 Normalized Maximum Transient Thermal Impedance

Test Circuit

1) E_{AS} test Circuit



2) Gate charge test Circuit

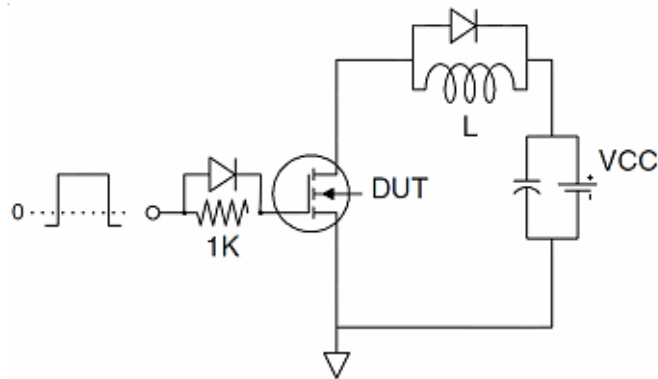

3) Switch Time Test Circuit

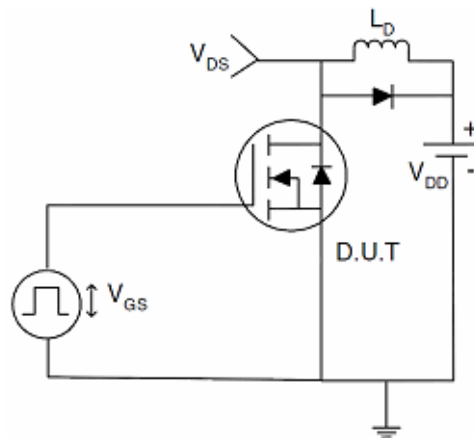

6. Marking (印章说明)

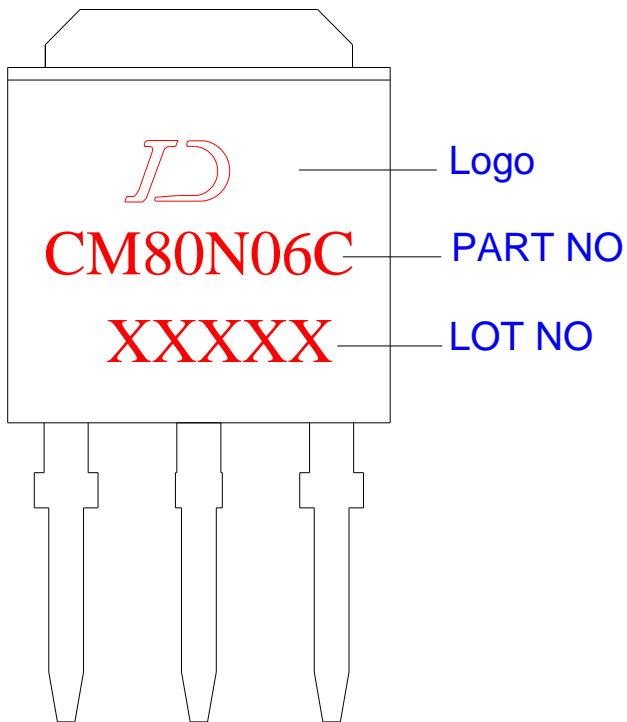

7. 产品外形尺寸图(单位: mm) Package Dimentions(Unit: mm)

T0-251S

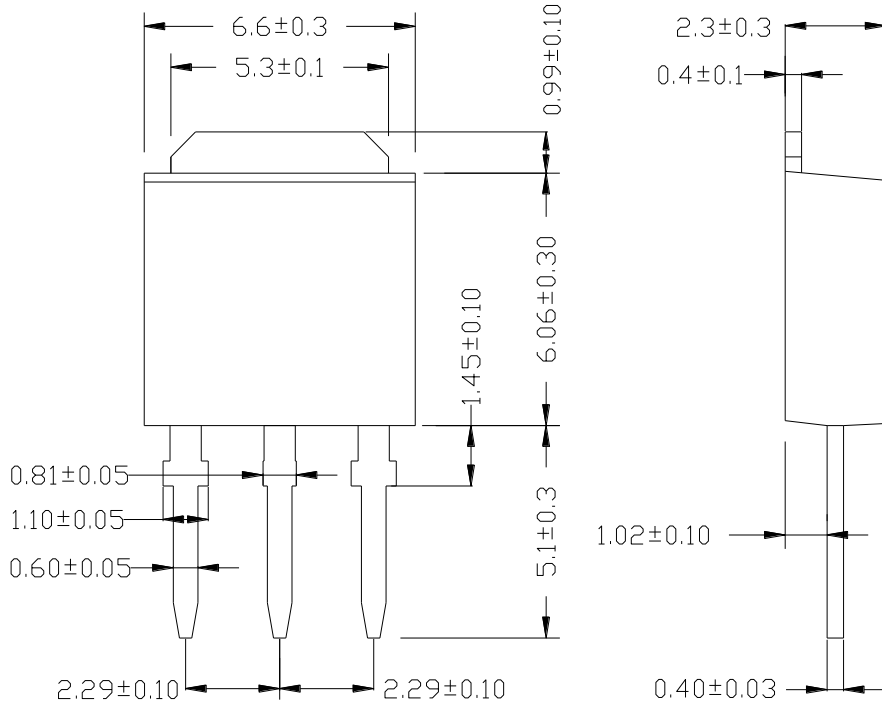

T0-252

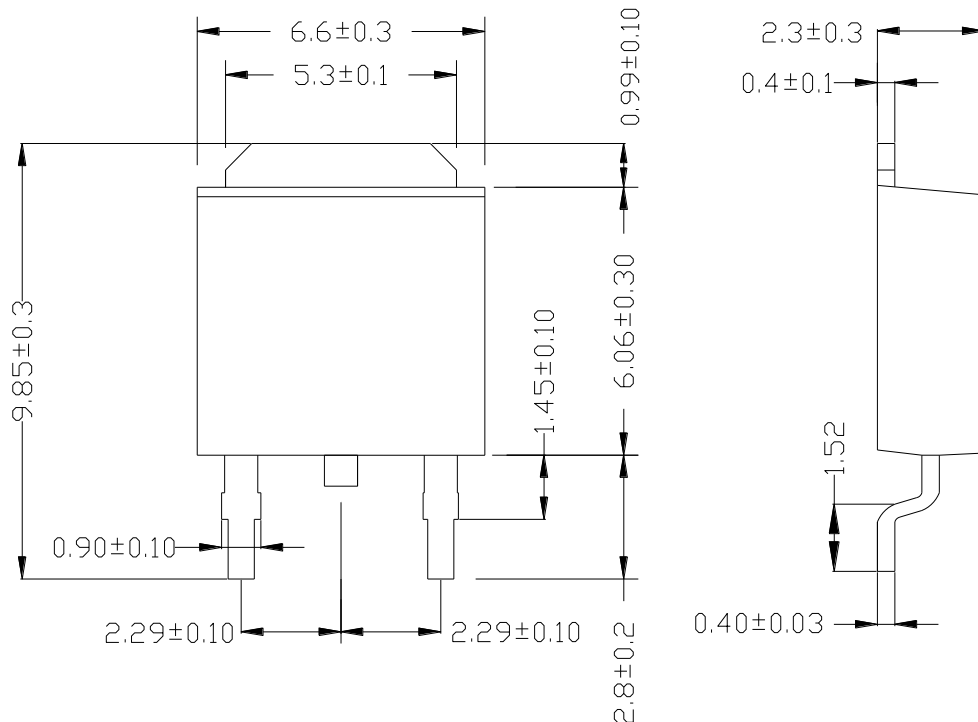

The name and content of poisonous and harmful material in products

Part's Name	Hazardous Substance					
	Pb	Hg	Cd	Cr(VI)	PBB	PBDE
Limit	≤0.1%	≤0.1%	≤0.01%	≤0.1%	≤0.1%	≤0.1%
Lead Frame	○	○	○	○	○	○
Molding Compound	○	○	○	○	○	○
Chip	○	○	○	○	○	○
Wire Bonding	○	○	○	○	○	○
Solder	×	○	○	○	○	○
Note	○: means the hazardous material is under the criterion of SJ/T11363-2006. ×: means the hazardous material exceeds the criterion of SJ/T11363-2006. The plumbum element of solder exist in products presently, but within the allowed range of Eurogroup's RoHS.					

Warnings

1. Exceeding the maximum ratings of the device in performance may cause damage to the device, even the permanent failure, which may affect the dependability of the machine. It is suggested to be used under 80 percent of the maximum ratings of the device.
2. When installing the heatsink, please pay attention to the torsional moment and the smoothness of the heatsink.
3. VDMOSFETs is the device which is sensitive to the static electricity, it is necessary to protect the device from being damaged by the static electricity when using it.
4. This publication is made by Jingdao Electronic and subject to regular change without notice.